



**comer industries**

powertrain

**POWERTRAIN  
SOLUTIONS**

10/17 EDITION

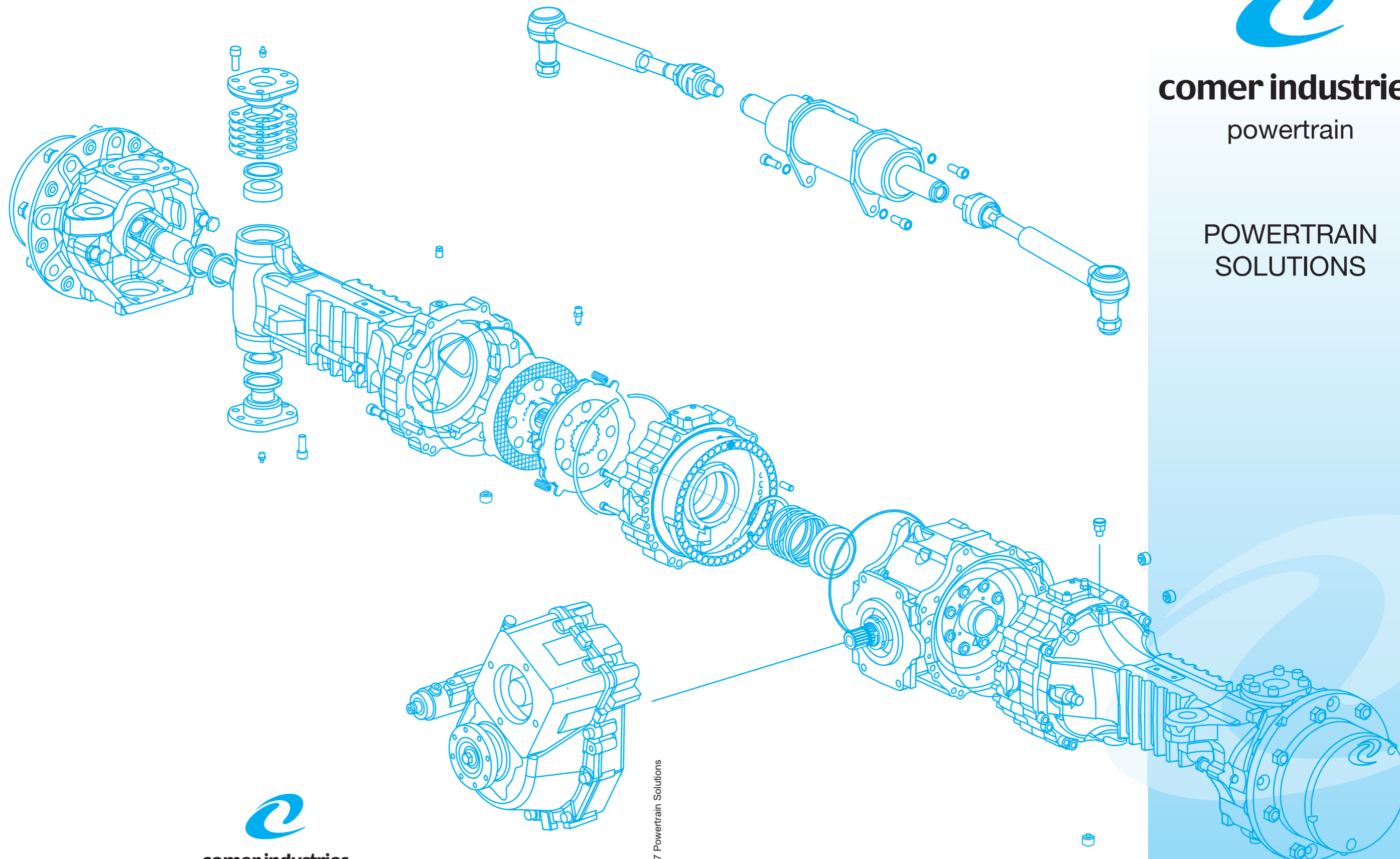

**comer industries**

powertrain

Comer Industries Spa







42046 Reggiolo (RE) Italy - Via Magellano, 27 - Tel. +39 0522 974111 - Fax +39 0522 973249

Updated information about our sales network and product ranges is available at: [www.comerindustries.com](http://www.comerindustries.com)  
Comer Industries shall have no liability for the completeness and accuracy of the information and cannot be held liable for any third-party claims or losses of any damages. The information represented in this catalogue can be revised at any time without notice.

CITEC 10/17 Powertrain Solutions



**comer industries**

		Applicazioni Applications	Pag. Page
Profilo dell'azienda	<i>Company profil</i>		2
Questionario tecnico	<i>Technical application form</i>		4
Autobetoniera	<i>Concrete Mixer</i>		6
Dumper	<i>Dumper</i>		8
Caricatore frontale	<i>Front End Loader</i>		12
Carro miscelatore semovente	<i>Self-Propelled Feed Mixer</i>		16
Compattatore rullo singolo	<i>Single Drum Compactor</i>		18
Sollevatore telescopico	<i>Telehandler</i>		22
Escavatore	<i>Wheeled Excavator</i>		26
Gamma prodotti	<i>Product range</i>		30

Comer Industries è leader globale nelle **soluzioni di meccatronica** e nei **sistemi integrati** per la trasmissione di potenza, destinati ai **principali costruttori mondiali di macchine per l'agricoltura e l'industria**.

L'attività produttiva è strutturata su cinque stabilimenti in **Italia**, nelle province di Reggio Emilia, Mantova e a Matera - specializzate per linee di prodotto - e due in **Cina** (Pinghu) e **India** (Bangalore).

Per sviluppare e testare soluzioni all'avanguardia, Comer Industries si avvale del proprio **Centro Ricerche di Meccatronica**, nato nel 1996 e dotato delle ultime tecnologie e strumenti di sperimentazione.

Gli **stabilimenti** Comer Industries nel mondo sono stati progettati secondo i principi del **World Class Manufacturing (WCM)**, una metodologia produttiva integrata di ispirazione giapponese ma sviluppata negli USA negli anni '90 che coinvolge l'intera organizzazione, dalla sicurezza all'ambiente, dalla manutenzione alla logistica e alla qualità, con l'obiettivo della sistematica riduzione degli sprechi per ottenere zero difetti, zero guasti, zero incidenti e zero scorte.

Comer Industries progetta e realizza **trasmissioni altamente personalizzate, versatili ed evolute**, come riduttori epicicloidali modulari, motoruote epicicloidali, riduttori epicicloidali per rotazione, riduttori epicicloidali speciali per applicazioni industriali, assali rigidi e sterzanti, destinati a macchine operatrici mobili e impianti fissi industriali.

La linea di prodotti **Powertrain** è stata sviluppata per fornire ai costruttori **soluzioni e sistemi completi** per l'intera driveline, con una vasta gamma di **assali rigidi e sterzanti**, con o senza riduzione epicicloidale, in combinazione con le più moderne **trasmissioni idrostatiche**.

Il loro impiego principale è nel settore delle macchine stradali, movimento terra e per l'edilizia, dei carrelli elevatori e delle attrezzature per la movimentazione materiali, delle attrezzature aeroportuali, delle macchine per municipalità, di gru e macchine per il sollevamento, da miniera e delle macchine forestali e agricole.

Comer Industries presidia i principali mercati esteri con le proprie **filiali commerciali** in Francia, Germania, Regno Unito, Stati Uniti, Brasile, Cina e India.



Comer Industries is a global leader in **mechatronic solutions** and **integrated systems for power transmission**, supplied to **major manufacturers of agricultural and industrial machinery** worldwide.

**Industrial operations** are structured in five plants in **Italy**, specialized by product line, plus two facilities in **China (Pinghu)** and **India (Bangalore)**.

To develop and test advanced product solutions, Comer Industries relies on its **Mechatronics Research Center**, established in 1996 and equipped with the latest technologies and experimental tools.

Comer Industries plants worldwide have been designed following the principles of **World Class Manufacturing (WCM)**, a Japanese work-based integrated production methodology developed in the USA in the 1990s which involves the entire organization, from safety to environment, maintenance, logistics and quality. It targets the elimination of all wastes with the ultimate objective of achieving zero defects, zero accidents, zero breakdowns and zero inventory.

Comer Industries designs and manufactures **highly customized, adaptable** and **advanced transmissions**, such as planetary drives, wheel drives, slew drives, planetary drives for special industrial applications, rigid and steering axles for mobile operating machinery and stationary plants.

The **Powertrain** product line has been developed to support OEM's with **full driveline system product solutions** thanks to an extensive range of **rigid and steering axles**, with or without planetary reduction, in combination with the latest technology of **hydrostatic transmissions**. These products are mainly used to drive road construction & earth moving equipment, forklift trucks and material handling equipment, airport equipment, municipality equipment, construction, cranes and lifting equipment, forestry, mining and agricultural equipment.

The company operates in the major world markets through its own **sales subsidiaries** in France, Germany, United Kingdom, United States, Brazil, China and India.

**Comer Academy**, the in-house management school, promotes **human resources** growth through training programs and attracts young, creative talents.



AZIENDA \_\_\_\_\_ Numero di telefono \_\_\_\_\_  
 Indirizzo \_\_\_\_\_ E-mail \_\_\_\_\_  
 Contatto \_\_\_\_\_ Data \_\_\_\_\_

Tipo di veicolo \_\_\_\_\_ Consegna prototipo \_\_\_\_\_  
 Quantità anno (unità) \_\_\_\_\_ Inizio produzione \_\_\_\_\_

**Tipo di applicazione**

Distribuzione dei pesi	a vuoto	a carico	picco <sup>(1)</sup>	rimorchio
Anteriore [Kg]				
Posteriore [Kg]				
Totale <sup>(2)</sup> [Kg]				
Velocità [Km/h]				
Pendenza [%]				
Forza di trazione [Kg]				

<sup>(1)</sup> Break-Out anteriore, Crowd posteriore, altro - <sup>(2)</sup> si intende anteriore + posteriore

Peso massimo su singola ruota (DX/SX se asim.) [kg]

	anteriore	posteriore

**Motore**

Potenza [kW] \_\_\_\_\_ '@ [rpm] \_\_\_\_\_  
 Coppia [daNm] \_\_\_\_\_ '@ [rpm] \_\_\_\_\_

**Pompa trasmissione Idr.**

Cilindrata minima [cc] \_\_\_\_\_  
 Cilindrata massima [cc] \_\_\_\_\_  
 Pressione max @ rpm [bar] \_\_\_\_\_  
 Velocità max [rpm] \_\_\_\_\_

**Motore trasmissione Idr.**

Cilindrata minima [cc] \_\_\_\_\_  
 Cilindrata massima [cc] \_\_\_\_\_  
 Pressione max [bar] \_\_\_\_\_  
 Coppia uscita @ rpm [daNm] \_\_\_\_\_  
 Velocità massima [rpm] \_\_\_\_\_

**Convertitore rapporto stallo**

Massima coppia uscita [daNm] \_\_\_\_\_ :1

**Modello frizione**

Coppia slittamento [daNm] \_\_\_\_\_

**Cambio sincronizzato**

Rapporto massimo \_\_\_\_\_ :1  
 Rapporto minimo \_\_\_\_\_ :1

**Dimensioni**

	anteriore	posteriore
Carreggiata a terra [mm]		
Fuori tutto pneumatici [mm]		
Altezza baricentro [mm]		
Passo [mm]		

**Duty Cycle**

Fase di lavoro	Tempo %	Vel. % <sup>(3)</sup>	Pend. % <sup>(3)</sup>
1.			
2.			
3.			
4.			
5.			
6.			
Vita attesa [ore]			

<sup>(3)</sup> percentuali rispetto ai valori a vuoto

**Pneumatici**

	anteriore	posteriore
Modello		
Raggio statico a carico [mm]		
Raggio di rotolamento [mm]		
Offset cerchioni ET <sup>(4)</sup> [mm]		
Riempimento (Aria, Acqua, Schiuma, etc.)		

<sup>(4)</sup> valori negativi per offset esterni

**Caratteristiche assali**

	Anteriore			Posteriore		
Folle / Traente	<input type="checkbox"/> Folle	<input type="checkbox"/> Traente		<input type="checkbox"/> Folle	<input type="checkbox"/> Traente	
Rigido / Sterzante	<input type="checkbox"/> Rigido	<input type="checkbox"/> Sterz.		<input type="checkbox"/> Rigido	<input type="checkbox"/> Sterz.	
Riduttore / Cambio afflangiato	<input type="checkbox"/> 1 marcia	<input type="checkbox"/> 2 marcie	<input type="checkbox"/> no	<input type="checkbox"/> 1 marcia	<input type="checkbox"/> 2 marcie	<input type="checkbox"/> no
Rapporto totale I <sup>a</sup> marcia - II <sup>a</sup> marcia	:1					
Distanza flangia a flangia piani cerchione [mm]						
Distanza fuori tutto [mm]						
Angolo massimo di sterzo [°]						
Attacco al telaio oscillante / rigido	<input type="checkbox"/> superiore	<input type="checkbox"/> centrale	<input type="checkbox"/> rigido	<input type="checkbox"/> superiore	<input type="checkbox"/> centrale	<input type="checkbox"/> rigido
Distanza piastre attacco telaio [mm]						
N° di colonnette ruota						
Diametro circonferenza dadi ruota [mm]						
Diametro di centraggio cerchione [mm]						
Tipo di differenziale	<input type="checkbox"/> aperto	<input type="checkbox"/> LS	<input type="checkbox"/> 100%	<input type="checkbox"/> aperto	<input type="checkbox"/> LS	<input type="checkbox"/> 100%
Freni di servizio [s/n]	<input type="checkbox"/> sì	<input type="checkbox"/> no		<input type="checkbox"/> sì	<input type="checkbox"/> no	
Tipo freni di servizio	<input type="checkbox"/> tamburo	<input type="checkbox"/> b. olio	<input type="checkbox"/> a disco	<input type="checkbox"/> tamburo	<input type="checkbox"/> b. olio	<input type="checkbox"/> a disco
Freno di parcheggio	<input type="checkbox"/> mecc.	<input type="checkbox"/> idr. neg.	<input type="checkbox"/> no	<input type="checkbox"/> mecc.	<input type="checkbox"/> idr. neg.	<input type="checkbox"/> no
Tipo freno di parcheggio	<input type="checkbox"/> tamburo	<input type="checkbox"/> b. olio	<input type="checkbox"/> a disco	<input type="checkbox"/> tamburo	<input type="checkbox"/> b. olio	<input type="checkbox"/> a disco

Barrare solo le opzioni prescelte

Decelerazione veicolo a carico @ velocità max [m/sec<sup>2</sup>] \_\_\_\_\_  
 Massima pendenza di stazionamento a carico [%] \_\_\_\_\_  
 Requisiti di omologazione \_\_\_\_\_



COMPANY \_\_\_\_\_ Phone number \_\_\_\_\_  
 Address \_\_\_\_\_ E-mail \_\_\_\_\_  
 Personal Contact \_\_\_\_\_ Date \_\_\_\_\_

Vehicle Model \_\_\_\_\_ Prototype delivery \_\_\_\_\_  
 Annual forecast (unit) \_\_\_\_\_ Start of Production \_\_\_\_\_

**Type of Vehicle**

Load Distribution		empty	laden	peak load <sup>(1)</sup>	towing
Front	[Kg]				
Rear	[Kg]				
Total <sup>(2)</sup>	[Kg]				
Speed	[Km/h]				
Slope	[%]				

<sup>(1)</sup> Break-Out front, Crowd rear, other operating condition - <sup>(2)</sup> must be front + rear

Tractive effort [daN] \_\_\_\_\_  
 front rear

Max weight on one wheel (if asymmetric LH-RH) [kg] \_\_\_\_\_  
 front rear

**Duty Cycle**

Operating mode	Time %	Speed % <sup>(3)</sup>	Slope % <sup>(3)</sup>
1.			
2.			
3.			
4.			
5.			
6.			
Total life [Hrs]			

<sup>(3)</sup> percentage are respect to empty condition

**Tires**

		front	rear
Model			
Static loaded radius	[mm]		
Rolling radius	[mm]		
Rim offset ET <sup>(4)</sup>	[mm]		
Filling (AIR, FOAM, WATER, SOLID, etc)			

<sup>(4)</sup> negative value stand for outward

**Engine model**

Max power [kW] \_\_\_\_\_ '@ [rpm] \_\_\_\_\_  
 Ma torque [daNm] \_\_\_\_\_ '@ [rpm] \_\_\_\_\_

**Hydrostatic Pump**

Min displacement [cc] \_\_\_\_\_  
 Max displacement [cc] \_\_\_\_\_  
 Max pressure @ rpm [bar] \_\_\_\_\_  
 Max speed [rpm] \_\_\_\_\_

**Hydrostatic Motor**

Min displacement [cc] \_\_\_\_\_  
 Max displacement [cc] \_\_\_\_\_  
 Max pressure [bar] \_\_\_\_\_  
 Output torque @ rpm [daNm] \_\_\_\_\_  
 Max speed [rpm] \_\_\_\_\_

**Torque converter stall ratio**

Max output torque [daNm] \_\_\_\_\_ :1

**Clutch model**

Slipping torque [daNm] \_\_\_\_\_

**Syncromesh gear**

Max ratio \_\_\_\_\_ :1  
 Min ratio \_\_\_\_\_ :1

**Dimensions**

		front	rear
Tire track	[mm]		
Overall tire width	[mm]		
Center of gravity heighth	[mm]		
Wheel base	[mm]		

**Axles feature**







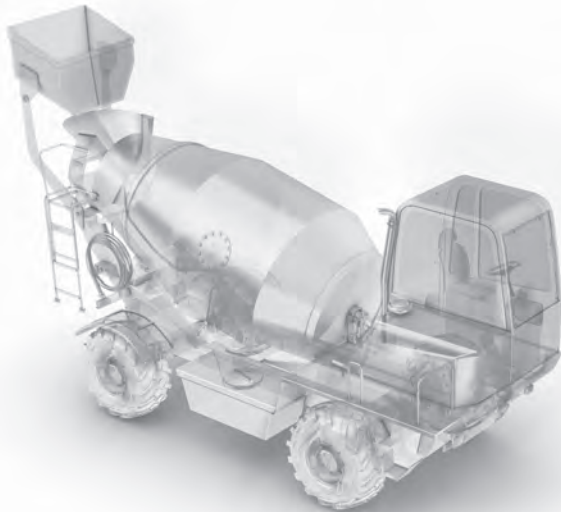





		Front			Rear		
Dead / Driven		<input type="checkbox"/> Dead	<input type="checkbox"/> Driven	<input type="checkbox"/> Dead	<input type="checkbox"/> Driven		
Rigid / Steering		<input type="checkbox"/> Rigid	<input type="checkbox"/> Steer.	<input type="checkbox"/> Rigid	<input type="checkbox"/> Steer.		
Flanged splitting gearbox		<input type="checkbox"/> 1 speed	<input type="checkbox"/> 2 speeds	<input type="checkbox"/> no	<input type="checkbox"/> 1 speed	<input type="checkbox"/> 2 speeds	<input type="checkbox"/> no
Total ratio 1st speed - 2nd speed	:1						
Rim planes (flange to flange) distance	[mm]						
Axles Overall	[mm]						
Max steering angle	[°]						
Frame mounting pivoting / rigid		<input type="checkbox"/> upper	<input type="checkbox"/> central	<input type="checkbox"/> rigid	<input type="checkbox"/> upper	<input type="checkbox"/> central	<input type="checkbox"/> rigid
Pads mounting distance	[mm]						
N° of studs							
Studs BCD	[mm]						
Pilot diameter	[mm]						
Differential type		<input type="checkbox"/> open	<input type="checkbox"/> LS	<input type="checkbox"/> 100%	<input type="checkbox"/> open	<input type="checkbox"/> LS	<input type="checkbox"/> 100%
Service brake	[y/n]	<input type="checkbox"/> yes	<input type="checkbox"/> no	<input type="checkbox"/> yes	<input type="checkbox"/> no		
Type of service brake		<input type="checkbox"/> drum	<input type="checkbox"/> wet	<input type="checkbox"/> dry	<input type="checkbox"/> drum	<input type="checkbox"/> wet	<input type="checkbox"/> dry
Parking brake		<input type="checkbox"/> Mech.	<input type="checkbox"/> S.A.H.R.	<input type="checkbox"/> no	<input type="checkbox"/> Mech.	<input type="checkbox"/> S.A.H.R.	<input type="checkbox"/> no
Type of parking brake		<input type="checkbox"/> drum	<input type="checkbox"/> wet	<input type="checkbox"/> dry	<input type="checkbox"/> drum	<input type="checkbox"/> wet	<input type="checkbox"/> dry

Tick only the selected option

Deceleration with laden vehicle @ max speed [m/sec<sup>2</sup>] \_\_\_\_\_  
 Max parking slope with laden vehicle [%] \_\_\_\_\_  
 Homologation requirements \_\_\_\_\_



- Elevati standard di performance per autobetoniere.
- High standards of performances for concrete mixers.

Cubatura Concrete yield [m <sup>3</sup> ]	Trasmissioni Transmissions		Assali Axles
	Doppia velocità Double speed	Singola velocità Single speed	
< 2.5	<b>S-528</b> 	<b>S-428</b>  <b>S-628</b> 	<b>S-128</b>   Anteriore/Front  Posteriore/Rear
2.5 ÷ 5.0	<b>S-528</b> 	<b>S-428</b>  <b>S-628</b> 	<b>S-238</b>   Anteriore/Front  Posteriore/Rear

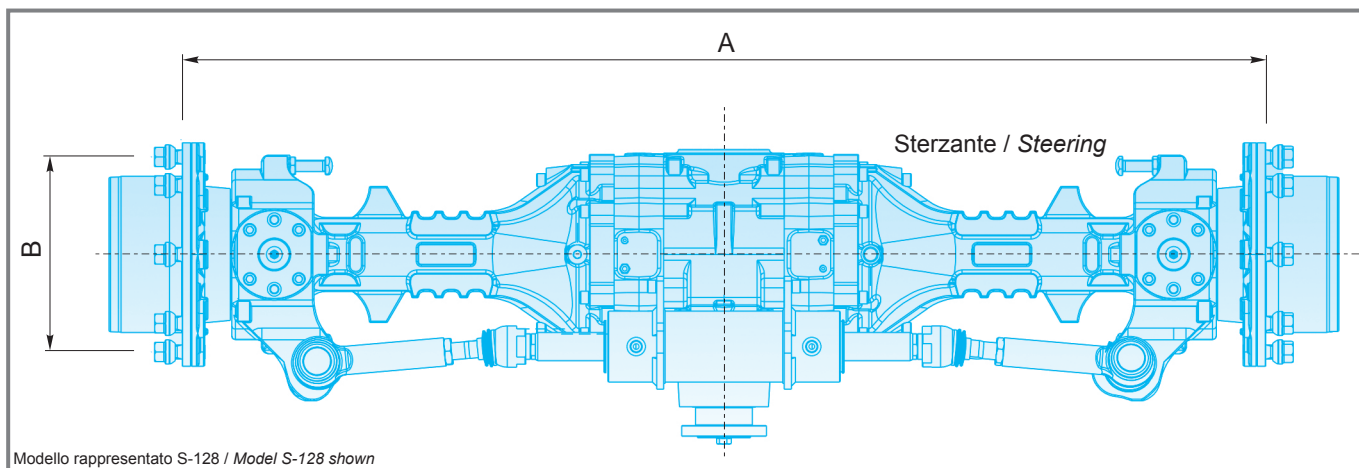

Modello rappresentato S-128 / Model S-128 shown

Assali Axles	Portata dinamica max. Max. dynamic load [daN]	Coppia max. Max. torque [daNm]	Rapp. rid. ruote Red. ratio wheels	Rapp. rid. totale Total red. ratio	A [mm]	B [mm]
<b>S-128</b>	5800	2400	6.00:1	13.41:1 ÷ 24.66:1	1530 ÷ 1810	∅ 275
<b>S-238</b>	9300	3400		1790 ÷ 2050	∅ 275 ∅ 335	

I valori di portata dinamica si riferiscono ad assali con montaggio oscillante / The dynamic load values refer to pivoting axles









Trasmissioni Transmission	Cilindrata motore Motor displacement [cc]	Numero velocità Number of speed	Rapp. rid. cambio Gearbox reduction ratio	Modalità cambio Shifting mode
<b>S-428</b>	up to 115	1	1.92:1 ÷ 2.50:1	n/a
<b>S-528</b>	up to 115	2	1.02:1 ÷ 4.78:1	Stand Still Easy Shift
<b>S-628</b>	up to 160	1	1.20:1 ÷ 2.46:1	n/a

I dati di cui sopra sono puramente indicativi. Le applicazioni individuali sono soggette alla approvazione della Comer Industries S.p.a.  
Above figures are an indication onl . Individual applications are subjects to approval by Comer Industries S.p.a.













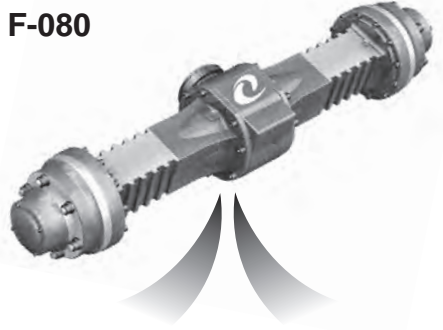





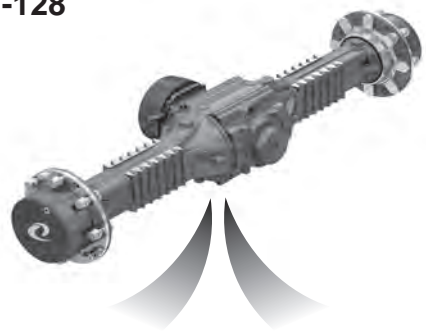

- Assali off-highway specificatamente progettati per dumper.
- *Specialized off-highway axles for dumpers.*

Capacità di carico <i>Load capacity</i> [t]	Trasmissioni <i>Transmissions</i>		Assali <i>Axles</i>
	Doppia velocità <i>Double speed</i>	Singola velocità <i>Single speed</i>	
< 2.0	-	<b>S-420</b> 	<b>F-046</b>   Anteriore/Front  Posteriore/Rear
2.0 ÷ 3.0	<b>S-500</b> 	<b>S-420</b> 	<b>F-068</b>   Anteriore/Front  Posteriore/Rear



Capacità di carico Load capacity [t]	Trasmissioni Transmissions		Assali Axles
	Doppia velocità Double speed	Singola velocità Single speed	
3.0 ÷ 4.5	<p><b>S-500</b></p> 	<p><b>S-420</b></p> 	<p><b>F-080</b></p>   <p>Anteriore/Front</p>  <p>Posteriore/Rear</p>
4.5 ÷ 7.0	<p><b>S-528</b></p> 	<p><b>S-428</b></p>  <p><b>S-628</b></p> 	<p><b>F-128</b></p>   <p>Anteriore/Front</p>  <p>Posteriore/Rear</p>
7.0 ÷ 10.0	<p><b>S-528</b></p> 	<p><b>S-428</b></p>  <p><b>S-628</b></p> 	<p><b>F-238</b></p>   <p>Anteriore/Front</p>  <p>Posteriore/Rear</p>

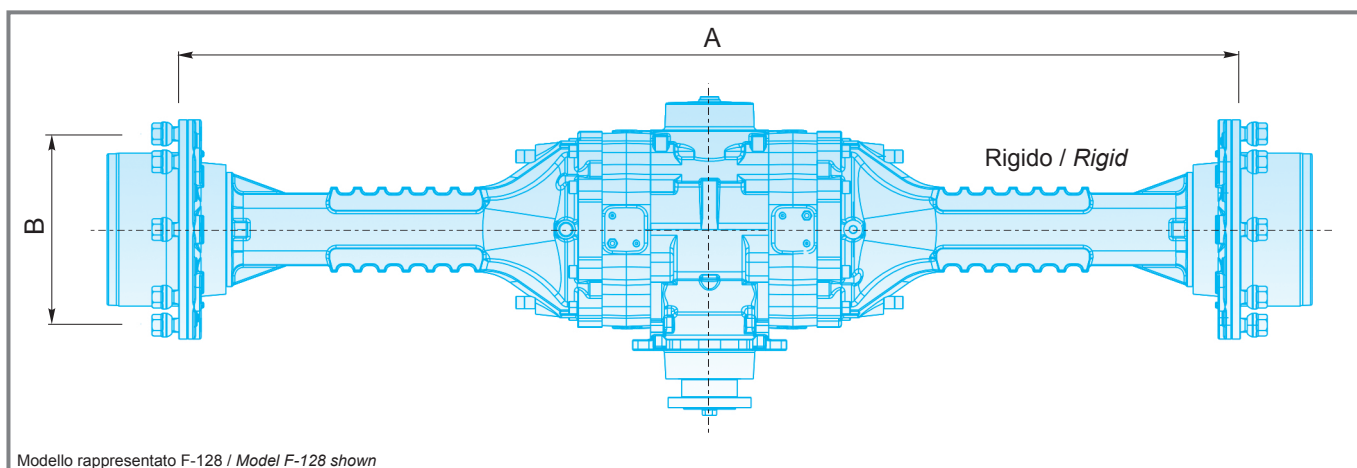

Assali Axles	Portata dinamica max. Max. dynamic load [daN]	Coppia max. Max. torque [daNm]	Rapp. rid. ruote Red. ratio wheels	Rapp. rid. totale Total red. ratio	A [mm]	B [mm]	
<b>F-046</b>	2500	440	-	2.23:1 ÷ 5.57:1	750 890	ø 205	
<b>F-068</b>	2700	850	4.31:1	9.63:1 ÷ 24.00:1	806 ÷ 1263		
<b>F-080</b>	4800	2100	4.80:1	10.73:1 ÷ 26.74:1	850 ÷ 1575		
<b>F-128</b>	5800	2400	6.00:1	13.41:1 ÷ 24.66:1	1010 ÷ 1810		ø 275
<b>F-238</b>	9300	3400			1660 ÷ 2050		ø 275 ø 335

I valori di portata dinamica si riferiscono ad assali con montaggio oscillante / The dynamic load values refer to pivoting axles







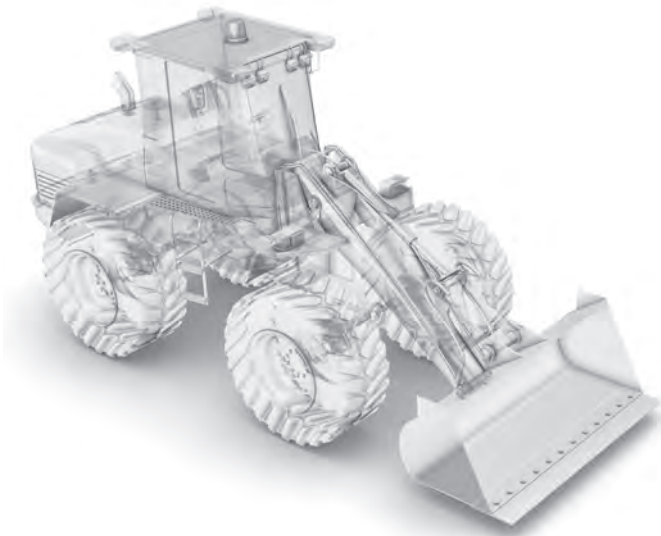

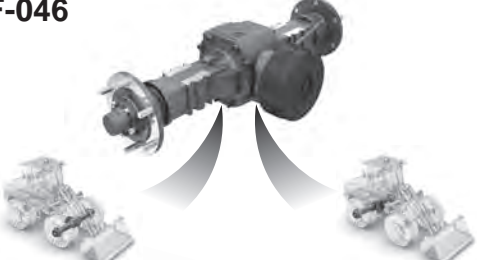

Trasmissioni <i>Transmission</i>	Cilindrata motore Motor displacement  [cc]	Numero velocità <i>Number of speed</i>	Rapp. rid. cambio <i>Gearbox reduction ratio</i>	Modalità cambio <i>Shifting mode</i>
<b>S-420</b>	up to 115	1	2.33:1 ÷ 4.56:1	n/a
<b>S-428</b>	up to 115	1	1.92:1 ÷ 2.50:1	n/a
<b>S-500</b>	up to 115	2	1.00:1 ÷ 5.11:1	Stand Still
<b>S-528</b>	up to 115	2	1.02:1 ÷ 4.78:1	Stand Still Easy Shift
<b>S-628</b>	up to 160	1	1.20:1 ÷ 2.46:1	n/a

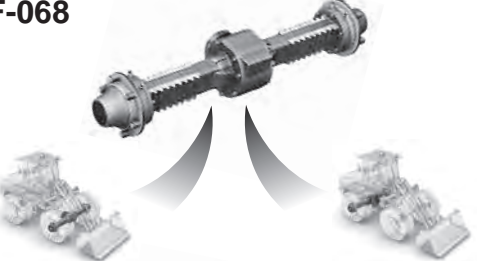

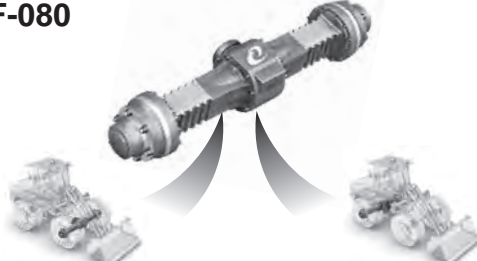



























I dati di cui sopra sono puramente indicativi. Le applicazioni individuali sono soggette alla approvazione della Comer Industries S.p.a.  
Above figures are an indication onl . Individual applications are subjects to approval by Comer Industries S.p.a.



- Assali off-highway specificatamente progettati per caricatori frontali.
- *Specialized off-highway axles for front end loaders.*

Peso a vuoto Empty vehicle weight [t]	Trasmissioni Transmissions		Assali Axles
	Doppia velocità Double speed	Singola velocità Single speed	
< 2.0	-	<b>S-420</b> 	<b>F-046</b>  Anteriore/Front      Posteriore/Rear
2.0 ÷ 3.0	<b>S-500</b> 	<b>S-420</b> 	<b>F-068</b>  Anteriore/Front      Posteriore/Rear
3.0 ÷ 4.5	<b>S-500</b> 	<b>S-420</b> 	<b>F-080</b>  Anteriore/Front      Posteriore/Rear
4.5 ÷ 6.5	<b>S-528</b> 	<b>S-428</b>  <b>S-628</b> 	<b>F-128</b>  Anteriore/Front      Posteriore/Rear



Peso a vuoto <i>Empty vehicle weight</i> [t]	Trasmissioni <i>Transmissions</i>		Assali <i>Axles</i>
	Doppia velocità <i>Double speed</i>	Singola velocità <i>Single speed</i>	
6.5 ÷ 7.5	<b>S-528</b> 	<b>S-428</b>  <b>S-628</b> 	<b>F-228</b>   Anteriore/Front  Posteriore/Rear
7.5 ÷ 8.5	<b>S-528</b> 	<b>S-428</b>  <b>S-628</b> 	<b>F-238</b>   Anteriore/Front  Posteriore/Rear
8.5 ÷ 9.5	<b>S-528</b> 	<b>S-428</b>  <b>S-628</b> 	<b>F-258</b>   Anteriore/Front  Posteriore/Rear
9.5 ÷ 10.5	<b>S-528</b> 	<b>S-428</b>  <b>S-628</b> 	<b>F-328</b>   Anteriore/Front  Posteriore/Rear
10.5 ÷ 12.0	<b>S-528</b> 	<b>S-428</b>  <b>S-628</b> 	<b>F-358</b>   Anteriore/Front  Posteriore/Rear

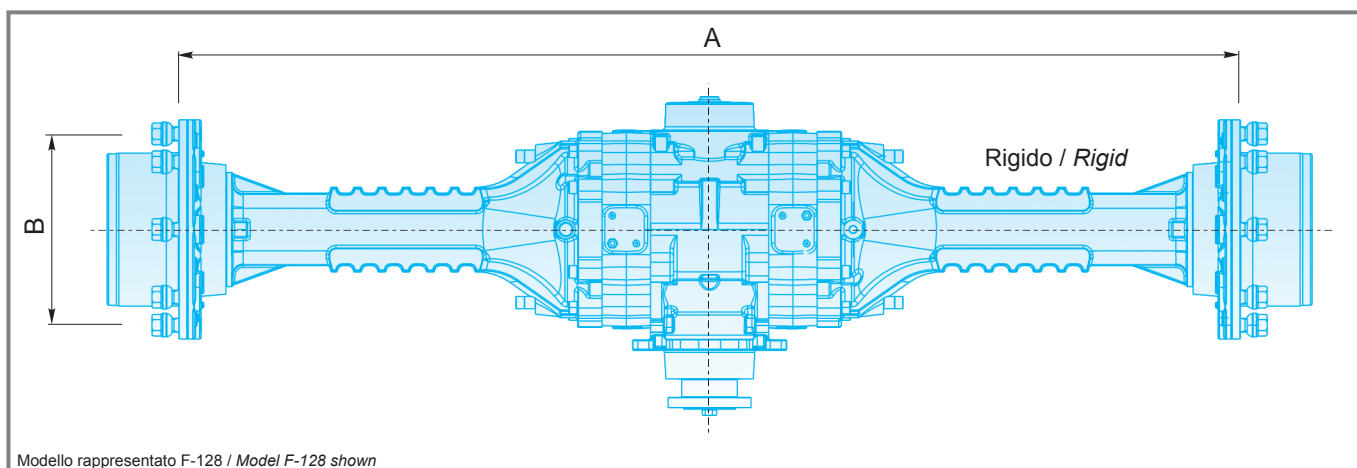

Modello rappresentato F-128 / Model F-128 shown

Assali Axles	Portata dinamica max. Max. dynamic load [daN]	Coppia max. Max. torque [daNm]	Rapp. rid. ruote Red. ratio wheels	Rapp. rid. totale Total red. ratio	A [mm]	B [mm]
<b>F-046</b>	2500	440	-	2.23:1 ÷ 5.57:1	750 890	
<b>F-068</b>	2700	850	4.31:1	9.63:1 ÷ 24.00:1	806 ÷ 1263	∅ 205
<b>F-080</b>	4800	2100	4.80:1	10.73:1 ÷ 26.74:1	850 ÷ 1575	
<b>F-128</b>	5800	2400			1010 ÷ 1810	∅ 275
<b>F-228</b>	8000	3400	6.00:1	13.41:1 ÷ 24.66:1		∅ 275 ∅ 335
<b>F-238</b>		3400			1660 ÷ 2050	
<b>F-258</b>	9300	4200		14.28:1 ÷ 26.30:1		∅ 335
<b>F-328</b>	12000	5300	6.40:1	13.72:1 ÷ 28.00:1	1660 ÷ 1920	
<b>F-358</b>	15000	6500		15.76:1 ÷ 28.00:1	1920 ÷ 2050	∅ 335 ∅ 425

I valori di portata dinamica si riferiscono ad assali con montaggio oscillante / The dynamic load values refer to pivoting axles



Trasmissioni <i>Transmission</i>	Cilindrata motore Motor displacement  [cc]	Numero velocità <i>Number of speed</i>	Rapp. rid. cambio <i>Gearbox reduction ratio</i>	Modalità cambio <i>Shifting mode</i>
<b>S-420</b>	up to 115	1	2.33:1 ÷ 4.56:1	n/a
<b>S-428</b>	up to 115	1	1.92:1 ÷ 2.50:1	n/a
<b>S-500</b>	up to 115	2	1.00:1 ÷ 5.11:1	Stand Still
<b>S-528</b>	up to 115	2	1.02:1 ÷ 4.78:1	Stand Still Easy Shift
<b>S-628</b>	up to 160	1	1.20:1 ÷ 2.46:1	n/a

I dati di cui sopra sono puramente indicativi. Le applicazioni individuali sono soggette alla approvazione della Comer Industries S.p.a.  
Above figures are an indication onl . Individual applications are subjects to approval by Comer Industries S.p.a.



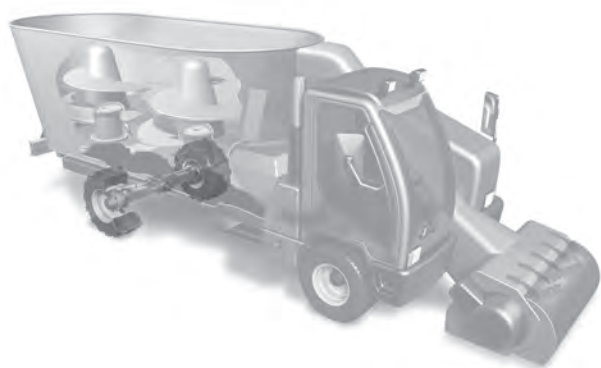

- Elevati standard di performance per carri miscelatori semoventi.
- *High standards of performances for self-propelled feed mixers.*

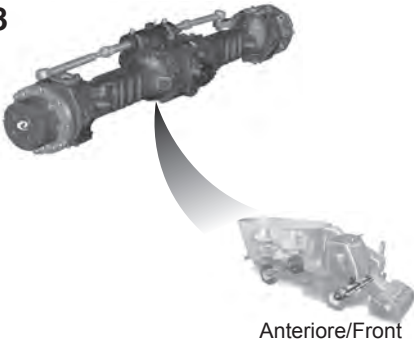
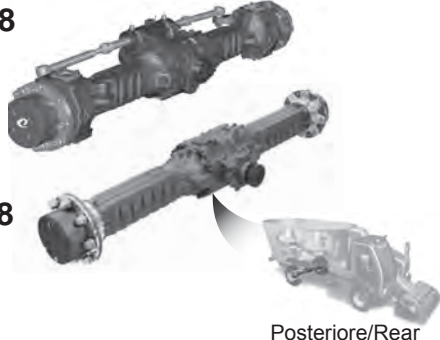
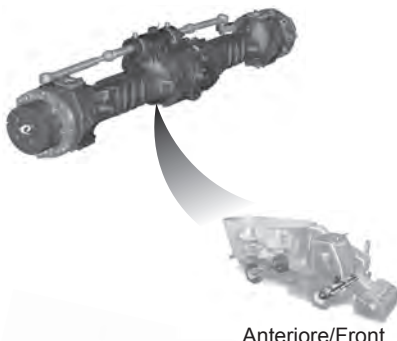
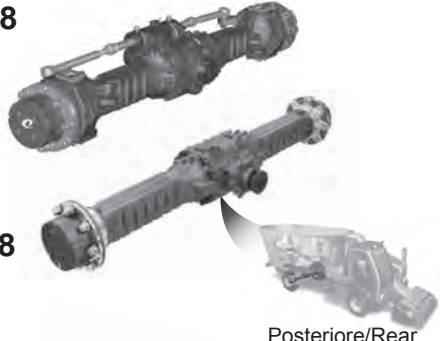
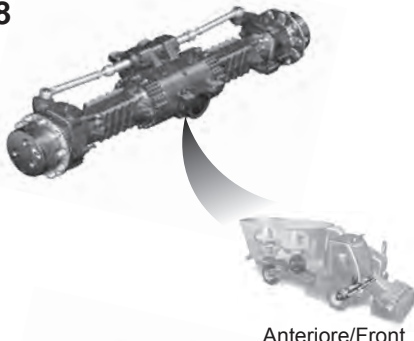
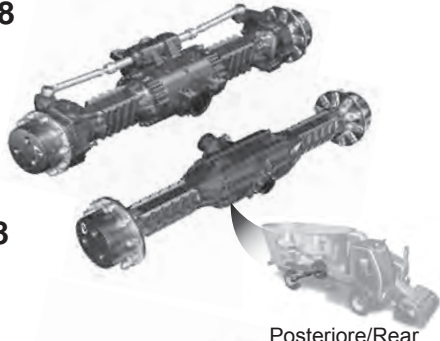
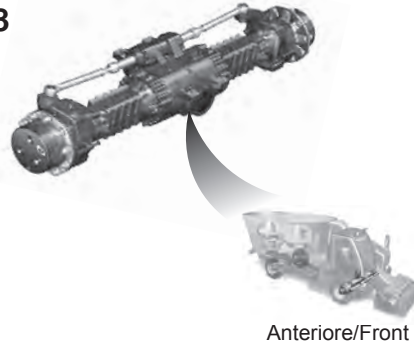
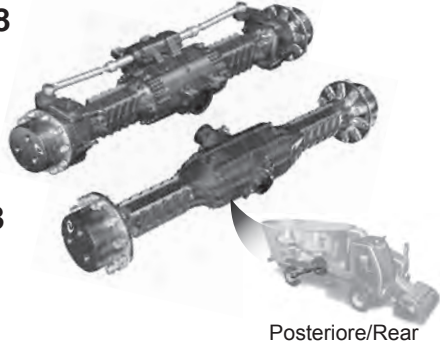
Cubatura Mixing capacity [m <sup>3</sup> ]	Assali anteriori Front axles	Assali posteriori Rear axles
<b>&lt; 14</b>	<b>S-228</b>  Anteriore/Front	<b>S-228</b>  <b>F-228</b> Posteriore/Rear
<b>14 ÷ 16</b>	<b>S-238</b>  Anteriore/Front	<b>S-238</b>  <b>F-238</b> Posteriore/Rear
<b>16 ÷ 20</b>	<b>S-328</b>  Anteriore/Front	<b>S-328</b>  <b>F-328</b> Posteriore/Rear
<b>20 ÷ 24</b>	<b>S-358</b>  Anteriore/Front	<b>S-358</b>  <b>F-358</b> Posteriore/Rear

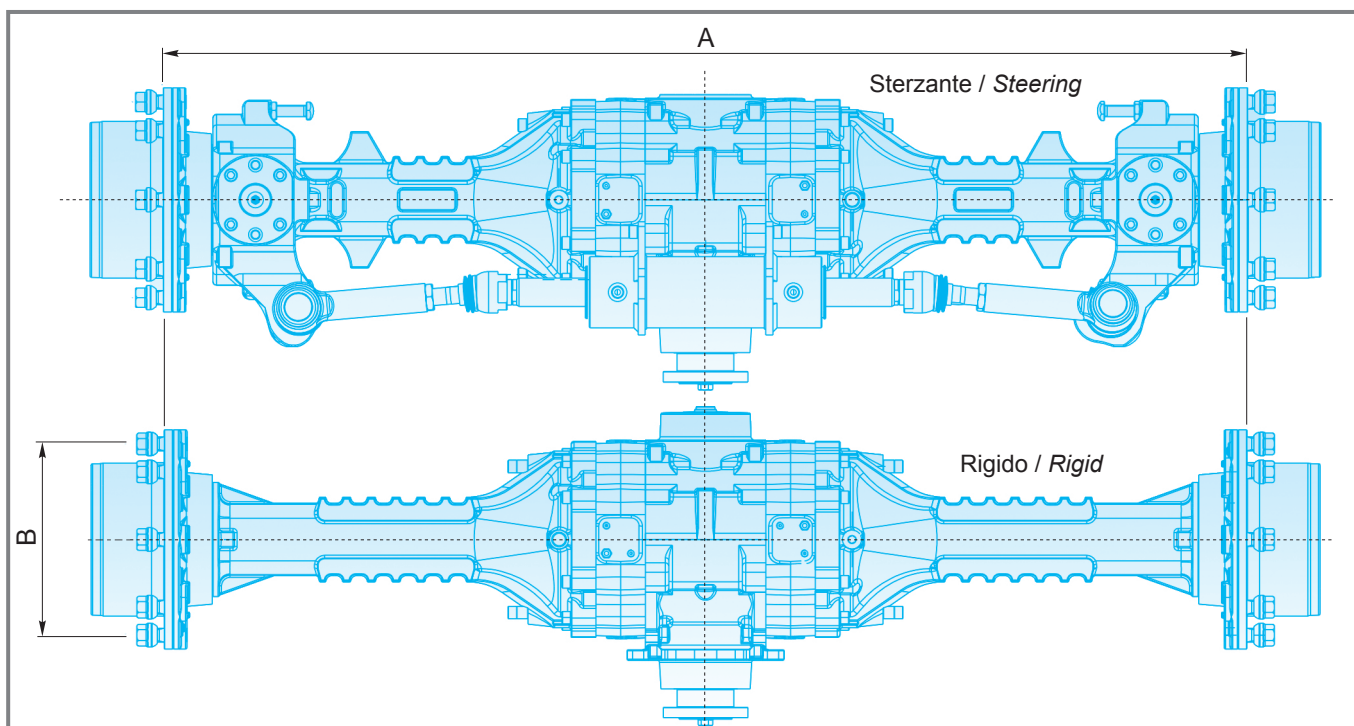

Modelli rappresentati S-128 e F-128 / Models S-128 and F-128 shown











Assali Axles	Portata dinamica max. Max. dynamic load [daN]	Coppia max. Max. torque [daNm]	Rapp. rid. ruote Red. ratio wheels	Rapp. rid. totale Total red. ratio	A [mm]	B [mm]
<b>S-228</b>	8000	3400	6.00:1	13.41:1 ÷ 24.66:1	1790 ÷ 2050	ø 275 ø 335
<b>F-228</b>						
<b>S-238</b>	9300					
<b>F-238</b>						
<b>S-328</b>	12000	5300	6.40:1	13.72:1 ÷ 28.00:1	1920 ÷ 2180	ø 335
<b>F-328</b>						
<b>S-358</b>	15000	6500		15.76:1 ÷ 28.00:1	2050 ÷ 2310	ø 335 ø 425
<b>F-358</b>						

I valori di portata dinamica si riferiscono ad assali con montaggio oscillante / The dynamic load values refer to pivoting axles















I dati di cui sopra sono puramente indicativi. Le applicazioni individuali sono soggette alla approvazione della Comer Industries S.p.a.  
Above figures are an indication onl . Individual applications are subjects to approval by Comer Industries S.p.a.



- Elevati standard di performance per compattatori single drum.
- *High standards of performances for single drum compactors.*

Peso operativo Operating load [t]	Trasmissioni Transmissions		Assali Axles
	Doppia velocità Double speed	Singola velocità Single speed	
< 7.0	-	<b>S-428</b>  <b>S-628</b>  <b>PG161</b> 	<b>F-128</b>   Posteriore/Rear
7.0 ÷ 10.0	-	<b>S-428</b>  <b>S-628</b>  <b>PG161</b> 	<b>F-228</b>   Posteriore/Rear



Peso operativo <i>Operating load</i> [t]	Trasmissioni <i>Transmissions</i>		Assali <i>Axles</i>
	Doppia velocità <i>Double speed</i>	Singola velocità <i>Single speed</i>	
10.0 ÷ 12.0	-	<b>S-428</b>  <b>S-628</b>  <b>PG161</b> 	<b>F-258</b>   Posteriore/Rear
12.0 ÷ 14.0	-	<b>S-428</b>  <b>S-628</b>  <b>PG161</b> 	<b>F-328</b>   Posteriore/Rear
14.0 ÷ 18.0	-	<b>S-428</b>  <b>S-628</b>  <b>PG161</b> 	<b>F-358</b>   Posteriore/Rear

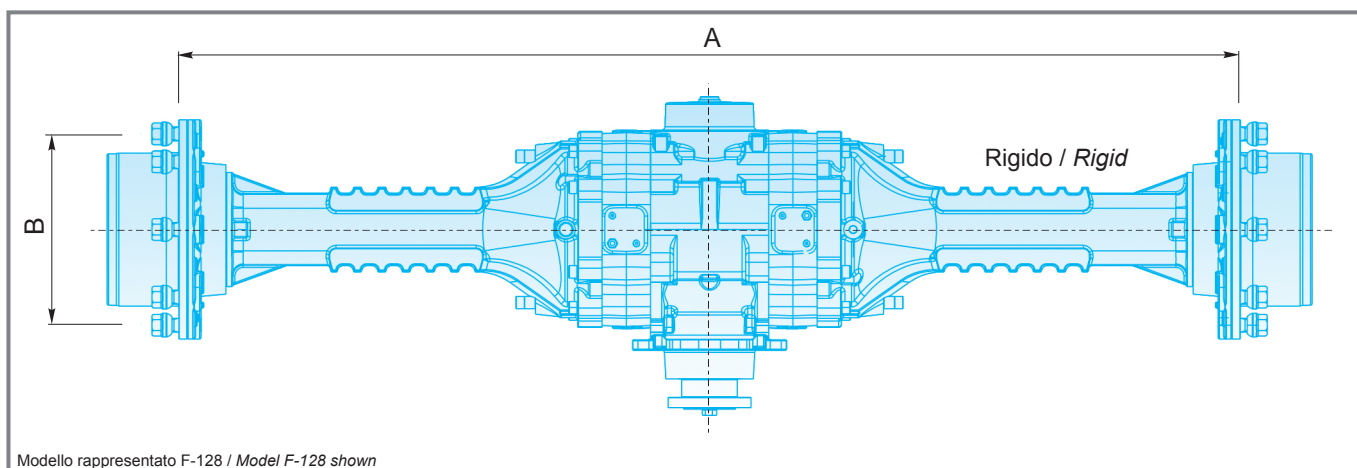

Assali Axles	Portata dinamica max. Max. dynamic load [daN]	Coppia max. Max. torque [daNm]	Rapp. rid. ruote Red. ratio wheels	Rapp. rid. totale Total red. ratio	A [mm]	B [mm]	
<b>F-128</b>	5800	2400	6.00:1	13.41:1 ÷ 24.66:1	1010 ÷ 1530	ø 275	
<b>F-228</b>	8000	3400			1660 ÷ 2050	ø 275 ø 335	
<b>F-258</b>	9300	4200	6.40:1	14.28:1 ÷ 26.30:1	1660 ÷ 1920	ø 335	
<b>F-328</b>	12000	5300				15.76:1 ÷ 28.00:1	ø 335
<b>F-358</b>	15000	6500				15.76:1 ÷ 28.00:1	1920 ÷ 2050

I valori di portata dinamica si riferiscono ad assali con montaggio oscillante / The dynamic load values refer to pivoting axles













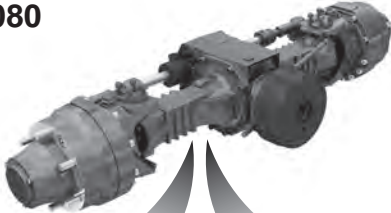





Trasmissioni <i>Transmission</i>	Cilindrata motore Motor displacement  [cc]	Numero velocità <i>Number of speed</i>	Rapp. rid. cambio <i>Gearbox reduction ratio</i>	Modalità cambio <i>Shifting mode</i>
<b>S-428</b>	up to 115	1	1.92:1 ÷ 2.50:1	n/a
<b>S-628</b>	up to 160	1	1.20:1 ÷ 2.46:1	n/a
<b>PG161</b>	up to 90	1	up to 6.75:1	n/a

























I dati di cui sopra sono puramente indicativi. Le applicazioni individuali sono soggette alla approvazione della Comer Industries S.p.a.  
Above figures are an indication onl . Individual applications are subjects to approval by Comer Industries S.p.a.



- Elevati standard di performance per sollevatori telescopici.
- *High standards of performances for telehandlers.*

Capacità di sollevamento <i>Lifting capacity</i> [Klbs]	Trasmissioni <i>Transmissions</i>		Assali <i>Axles</i>
	Doppia velocità <i>Double speed</i>	Singola velocità <i>Single speed</i>	
< 4.0	<b>S-500</b> 	<b>S-420</b> 	<b>S-080</b>   Anteriore/Front  Posteriore/Rear
4.0 ÷ 6.5	<b>S-528</b> 	<b>S-428</b>  <b>S-628</b> 	<b>S-128</b>   Anteriore/Front  Posteriore/Rear
6.5 ÷ 8.0	<b>S-528</b> 	<b>S-428</b>  <b>S-628</b> 	<b>S-228</b>   Anteriore/Front  Posteriore/Rear



Capacità di sollevamento <i>Lifting capacity</i> [Klbs]	Trasmissioni <i>Transmissions</i>		Assali <i>Axles</i>
	Doppia velocità <i>Double speed</i>	Singola velocità <i>Single speed</i>	
8.0 ÷ 9.0	<b>S-528</b> 	<b>S-428</b>  <b>S-628</b> 	<b>S-238</b>   Anteriore/Front  Posteriore/Rear
9.0 ÷ 10.0	<b>S-528</b> 	<b>S-428</b>  <b>S-628</b> 	<b>S-258</b>   Anteriore/Front  Posteriore/Rear
10.0 ÷ 11.0	<b>S-528</b> 	<b>S-428</b>  <b>S-628</b> 	<b>S-328</b>   Anteriore/Front  Posteriore/Rear
11.0 ÷ 14.0	<b>S-528</b> 	<b>S-428</b>  <b>S-628</b> 	<b>S-358</b>   Anteriore/Front  Posteriore/Rear



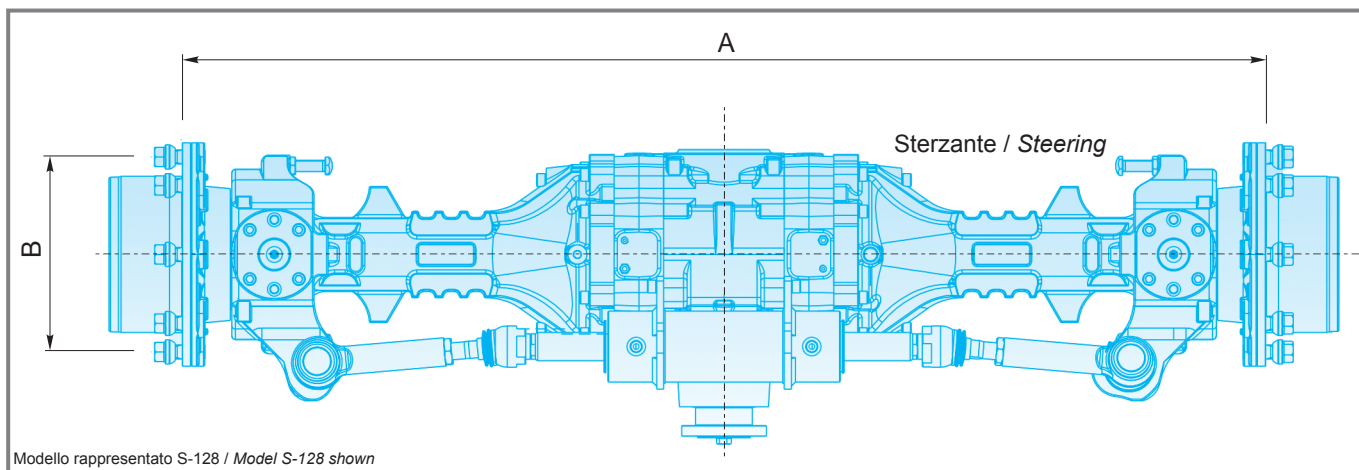

Modello rappresentato S-128 / Model S-128 shown

Assali Axles	Portata dinamica max. Max. dynamic load [daN]	Coppia max. Max. torque [daNm]	Rapp. rid. ruote Red. ratio wheels	Rapp. rid. totale Total red. ratio	A [mm]	B [mm]
<b>S-080</b>	2700	2100	4.80:1	10.73:1 ÷ 26.74:1	1272 ÷ 1440	∅ 205
<b>S-128</b>	5800	2400	6.00:1	13.41:1 ÷ 24.66:1	1250 ÷ 1810	∅ 275
<b>S-228</b>	8000	3400	6.00:1		1660 ÷ 2050	∅ 275 ∅ 335
<b>S-238</b>	9300					
<b>S-258</b>	9300	4200	6.40:1	14.28:1 ÷ 26.30:1	1920 ÷ 2180	∅ 335
<b>S-328</b>	12000	5300		13.72:1 ÷ 28.00:1		
<b>S-358</b>	15000	6500		15.76:1 ÷ 28.00:1		

I valori di portata dinamica si riferiscono ad assali con montaggio oscillante / The dynamic load values refer to pivoting axles







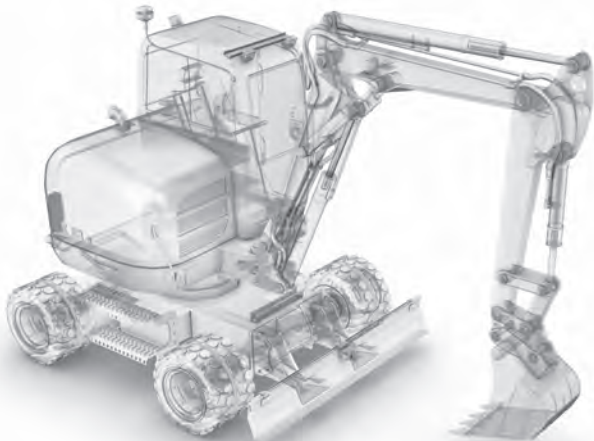









Trasmissioni <i>Transmission</i>	Cilindrata motore Motor displacement  [cc]	Numero velocità <i>Number of speed</i>	Rapp. rid. cambio <i>Gearbox reduction ratio</i>	Modalità cambio <i>Shifting mode</i>
<b>S-420</b>	up to 115	1	2.33:1 ÷ 4.56:1	n/a
<b>S-428</b>	up to 115	1	1.92:1 ÷ 2.50:1	n/a
<b>S-500</b>	up to 115	2	1.00:1 ÷ 5.11:1	Stand Still
<b>S-528</b>	up to 115	2	1.02:1 ÷ 4.78:1	Stand Still Easy Shift
<b>S-628</b>	up to 160	1	1.20:1 ÷ 2.46:1	n/a









I dati di cui sopra sono puramente indicativi. Le applicazioni individuali sono soggette alla approvazione della Comer Industries S.p.a.  
Above figures are an indication onl . Individual applications are subjects to approval by Comer Industries S.p.a.

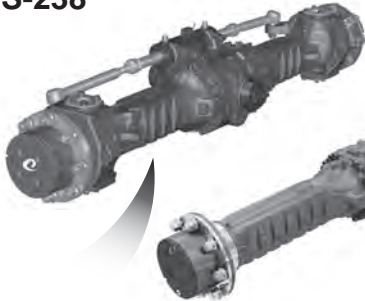

- Assali off-highway specificatamente progettati per escavatori.
- *Specialized off-highway axles for wheeled excavators.*

Peso operativo Operating load [t]	Trasmissioni Transmissions		Assali Axles
	Doppia velocità Double speed	Singola velocità Single speed	
< 8.0	<b>S-528</b> 	<b>S-428</b>  <b>S-628</b> 	<b>S-128</b>  <b>F-128</b>  Anteriore/Front  Posteriore/Rear 
8.0 ÷ 12.0	<b>S-528</b> 	<b>S-428</b>  <b>S-628</b> 	<b>S-228</b>  <b>F-228</b>  Anteriore/Front  Posteriore/Rear 



Peso operativo Operating load [t]	Trasmissioni Transmissions		Assali Axles
	Doppia velocità Double speed	Singola velocità Single speed	
12.0 ÷ 15.0	<p><b>S-528</b></p> 	<p><b>S-428</b></p>  <p><b>S-628</b></p> 	<p><b>S-238</b></p>  <p><b>F-238</b></p>  <p>Anteriore/Front <span style="margin-left: 150px;">Posteriore/Rear</span></p>
15.0 ÷ 18.0	<p><b>S-528</b></p> 	<p><b>S-428</b></p>  <p><b>S-628</b></p> 	<p><b>S-328</b></p>  <p><b>F-328</b></p>  <p>Anteriore/Front <span style="margin-left: 150px;">Posteriore/Rear</span></p>

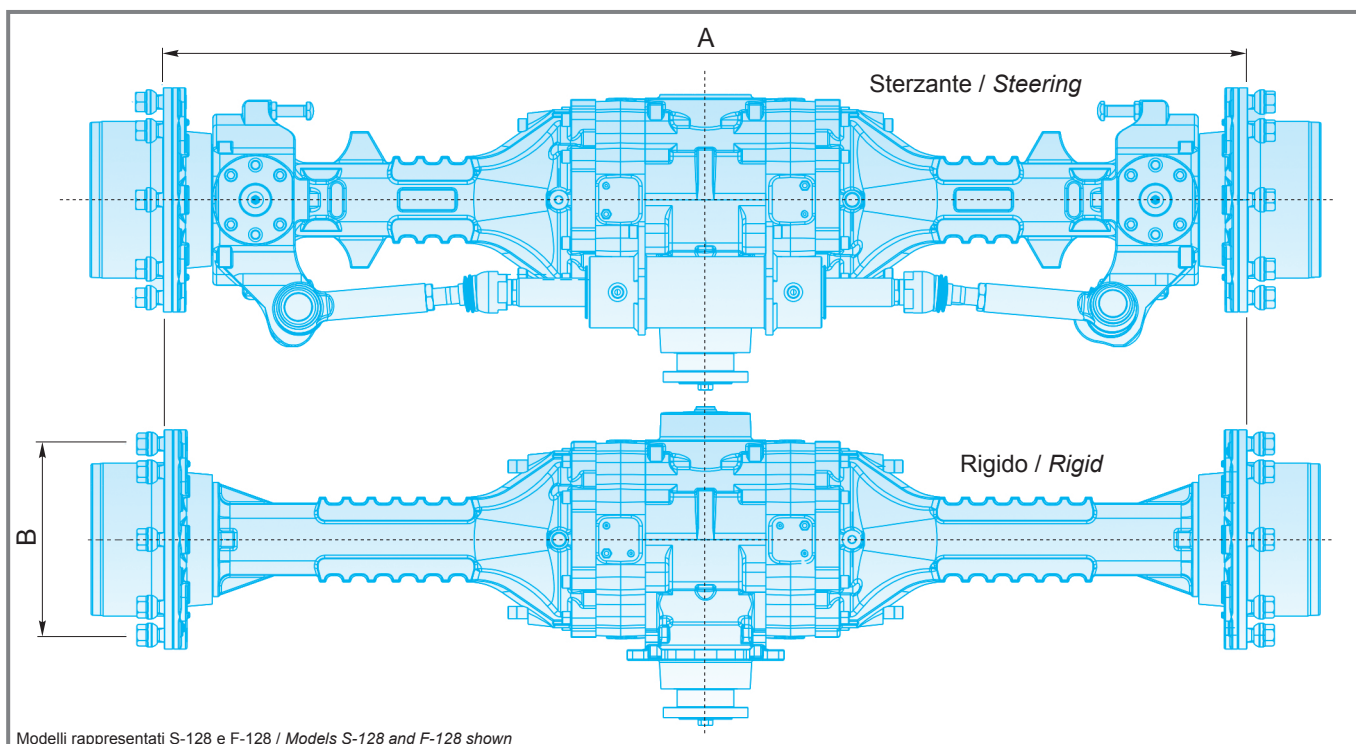

Modelli rappresentati S-128 e F-128 / Models S-128 and F-128 shown

Assali Axles	Portata dinamica max. Max. dynamic load [daN]	Coppia max. Max. torque [daNm]	Rapp. rid. ruote Red. ratio wheels	Rapp. rid. totale Total red. ratio	A [mm]	B [mm]		
<b>S-128</b>	5800	2400	6.00:1	13.41:1 ÷ 24.66:1	1390 ÷ 1810	ø 275		
<b>F-128</b>								
<b>S-228</b>	8000	3400						
<b>F-228</b>								
<b>S-238</b>	9300	3400			1790 ÷ 2050	ø 275 ø 335		
<b>F-238</b>								
<b>S-328</b>	12000	5300			6.40:1	13.72:1 ÷ 28.00:1	1850 ÷ 2050	ø 335
<b>F-328</b>								

I valori di portata dinamica si riferiscono ad assali con montaggio oscillante / The dynamic load values refer to pivoting axles



Trasmissioni <i>Transmission</i>	Cilindrata motore Motor displacement  [cc]	Numero velocità <i>Number of speed</i>	Rapp. rid. cambio <i>Gearbox reduction ratio</i>	Modalità cambio <i>Shifting mode</i>
<b>S-428</b>	up to 115	1	1.92:1 ÷ 2.50:1	n/a
<b>S-528</b>	up to 115	2	1.02:1 ÷ 4.78:1	Stand Still Easy Shift
<b>S-628</b>	up to 160	1	1.20:1 ÷ 2.46:1	n/a

I dati di cui sopra sono puramente indicativi. Le applicazioni individuali sono soggette alla approvazione della Comer Industries S.p.a.  
Above figures are an indication onl . Individual applications are subjects to approval by Comer Industries S.p.a.

Assali Axles		Portata din. max. Max. dyn. load [daN]	Coppia max. Max. torque [daNm]	Rapp. rid. ruote Red. ratio wheels	Range rapporto taglia assale Axles size range reduction ratio	B [mm]
Assali rigidi / Rigid axles	<b>F-046</b>	2500	440	-	2.23:1 ÷ 5.57:1	ø 205
	<b>F-068</b>	2700	850	4.31:1	9.63:1 ÷ 24.00:1	
	<b>F-080</b>	4800	2100	4.80:1	10.73:1 ÷ 26.74:1	
	<b>F-128</b>	5800	2400	6.00:1	13.41:1 ÷ 24.66:1	ø 275
	<b>F-228</b>	8000	3400			6.40:1
	<b>F-238</b>	9300		4200	13.72:1 ÷ 28.00:1	
	<b>F-258</b>		12000			5300
	<b>F-328</b>	15000		6500	6.40:1	
<b>F-358</b>	15000		6500			6.40:1
Assali sterzanti / Steering axles		<b>S-068</b>		2700	850	
	<b>S-080</b>	2700	2100	4.80:1	10.73:1 ÷ 26.74:1	ø 205
	<b>S-128</b>	5800	2400	6.00:1	13.41:1 ÷ 24.66:1	ø 275
	<b>S-228</b>	8000	3400			6.40:1
	<b>S-238</b>	9300		4200	13.72:1 ÷ 28.00:1	
	<b>S-258</b>		12000			5300
	<b>S-328</b>	15000		6500	6.40:1	
	<b>S-358</b>		15000			6500

I valori di portata dinamica si riferiscono ad assali con montaggio oscillante / The dynamic load values refer to pivoting axles

Trasmissioni <i>Transmission</i>	Cilindrata motore Motor displacement [cc]	Numero velocità <i>Number of speed</i>	Rapp. rid. cambio <i>Gearbox reduction ratio</i>	Modalità cambio <i>Shifting mode</i>	Flange
<b>S-420</b>	up to 115	1	2.33:1 ÷ 4.56:1	n/a	ASA100 DIN120
<b>S-428</b>	up to 115	1	1.92:1 ÷ 2.50:1	n/a	DIN120 END YOKE 1410
<b>S-500</b>	up to 115	2	1.00:1 ÷ 5.11:1	Stand Still	ASA100 DIN120
<b>S-528</b>	up to 115	2	1.02:1 ÷ 4.78:1	Stand Still Easy Shift	DIN120 END YOKE 1410
<b>S-628</b>	up to 160	1	1.20:1 ÷ 2.46:1	n/a	DIN120 END YOKE 1410
<b>PG161</b>	up to 90	1	up to 6.75:1	n/a	Direct motor adapter

I dati di cui sopra sono puramente indicativi. Le applicazioni individuali sono soggette alla approvazione della Comer Industries S.p.a.  
Above figures are an indication onl . Individual applications are subjects to approval by Comer Industries S.p.a.



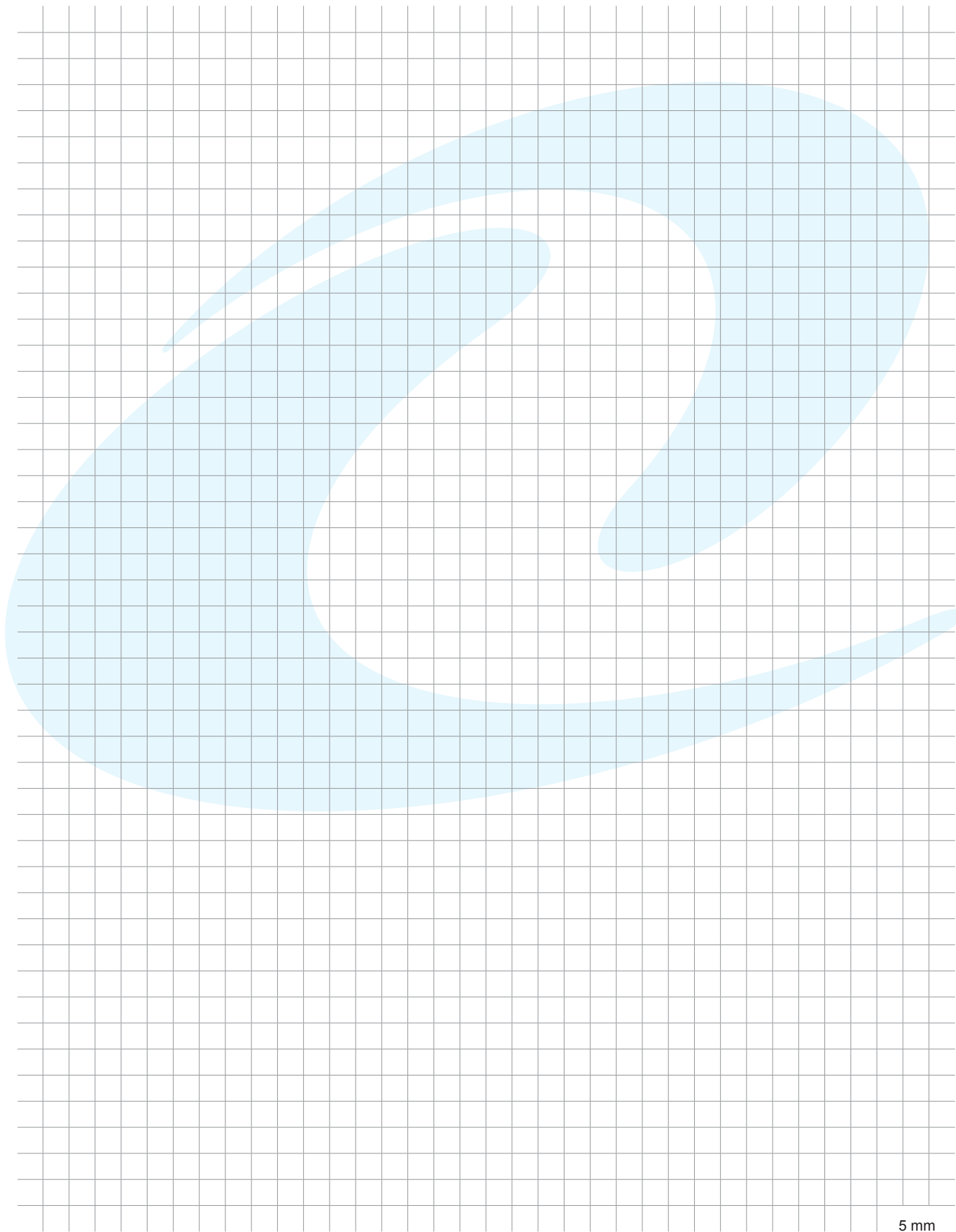

5 mm